

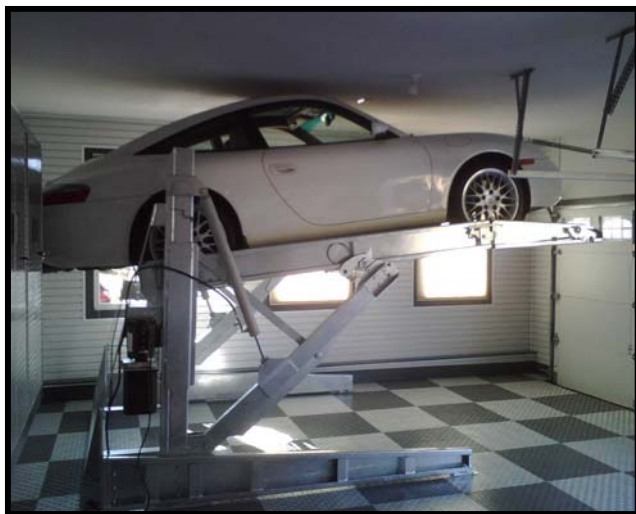

**HARDING
STEEL**

Car Lift by Harding Steel

Residential – Commercial – Indoor – Outdoor – Low Ceiling



Expand parking capacity with safe affordable parking lifts from Harding Steel

World-Class Lifts Since 1968



HARDING
STEEL

Car Lift Features

- 100% galvanized steel construction
- Commercial grade design and materials
- Dual hydraulic lifting cylinders
- Self-standing, self-supporting unit
- Can be moved or relocated
- Central or individual hydraulic power pack
- Solid steel platform prevents dripping from upper level
- Accommodates most popular SUVs and minivans
- Available in Tall, Low, Narrow, and Wide models
- Special SUV model available (shown at right)

Safety

- Standard key-lock switch for security and safety
- Automatic shut-off if operator releases the key-switch
- Steel-on steel locks hold the upper platform in place
- Manual lock release required to lower the unit

Dimensions

- **Typical ceiling heights**
 - Two Compacts 9'6"
 - Two Full Size 10'0"
 - One Full / One SUV 11'6"
 - Two SUVs (6' height) 12'10"
 - Two SUVs (6'3" height) 13'4"
- **Width (side-to-side dimension)**
 - 7'7" (narrow model)
 - 8'2" (standard model)
- **Length**
 - 12'4" (total parking lift length)
 - 11'7" (vehicle platform length)

Power Requirements

- 110V, 20 amp, single phase (for residential power pack)
- 220V, 20 amp, single phase (for residential power pack)
- 220V, 3-phase, 40 amp for commercial central power pack

Shipping and Installation

- Shipped by common carrier to most locations
- Installed by factory trained technicians

Warranty

- One year electrical, two year mechanical, five year structural

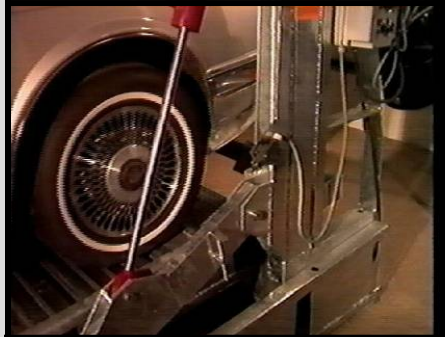



**HARDING
STEEL**

Harding Steel Car Lift

Residential – Commercial – Indoor – Outdoor – Low Ceiling

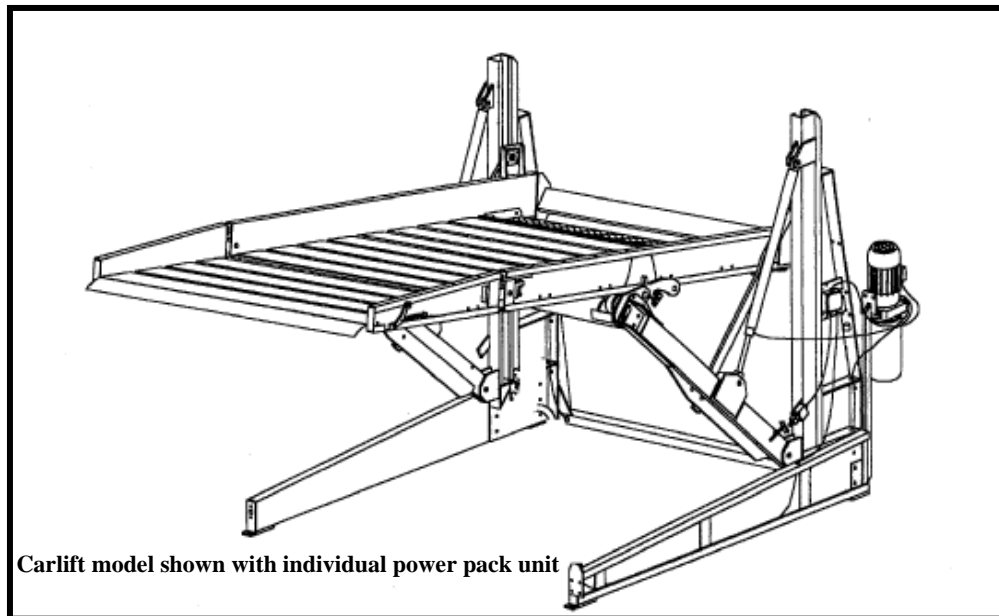

Carlift model shown with individual power pack unit

MODEL	A*	B*	C	D	E	F	G
Low-Narrow	4' 3"	5' 7"	7' 7"	12' 4"	11' 7"	6' 1"	8' 3"
Tall-Narrow	5' 7"	6' 11"	7' 7"	12' 4"	11' 7"	6' 1"	8' 3"
Low-Wide	4' 3"	5' 7"	8' 2"	12' 4"	11' 7"	6' 7"	8' 3"
Tall-Wide	5' 7"	6' 11"	8' 2"	12' 4"	11' 7"	6' 7"	8' 3"

Features

- 100% galvanized steel construction
- Commercial grade design and materials
- Dual hydraulic cylinders
- Self-standing, self-supporting unit
- Can be moved or relocated
- Individual or common hydraulic power pack
- Solid platform prevents dripping from upper level
- Accommodates most popular SUVs and minivans

Safety

- Individual operating switch per unit (optional key-lock)
- Automatic shut-off if operator releases the key-switch
- Steel-on steel locks hold the upper platform in place
- Manual lock release required to lower the unit

Power Requirements

- Common Power Packs: 40amp, 3phase, 220V
- Individual Power Pack: 110V, or 220V -single phase- 20amp

Dimensions

Typical ceiling heights

- Two Compacts 9'6"
- Two Full Size 10'0"
- One Full / One SUV 11'6"
- Two SUVs (6' height) 12'10"
- Two SUVs (6'3" height) 13'4"

Width (side-to-side dimension)

- 7'7" (narrow model)
- 8'2" (standard model)

Length

- 12'4" (total parking lift length)
- 11'7" (vehicle platform length)

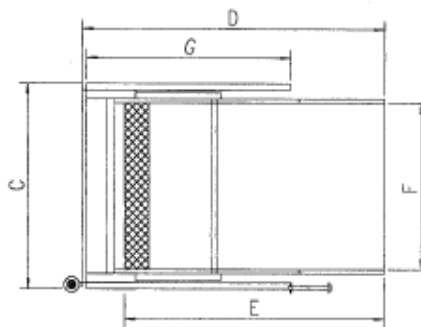

Plan View

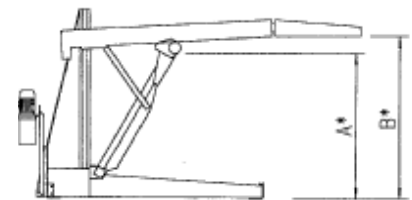

Cross Section



HARDING
STEEL

Harding Steel Tall Model Car Lifts

Ideal for areas with 10' or more of vertical clearance

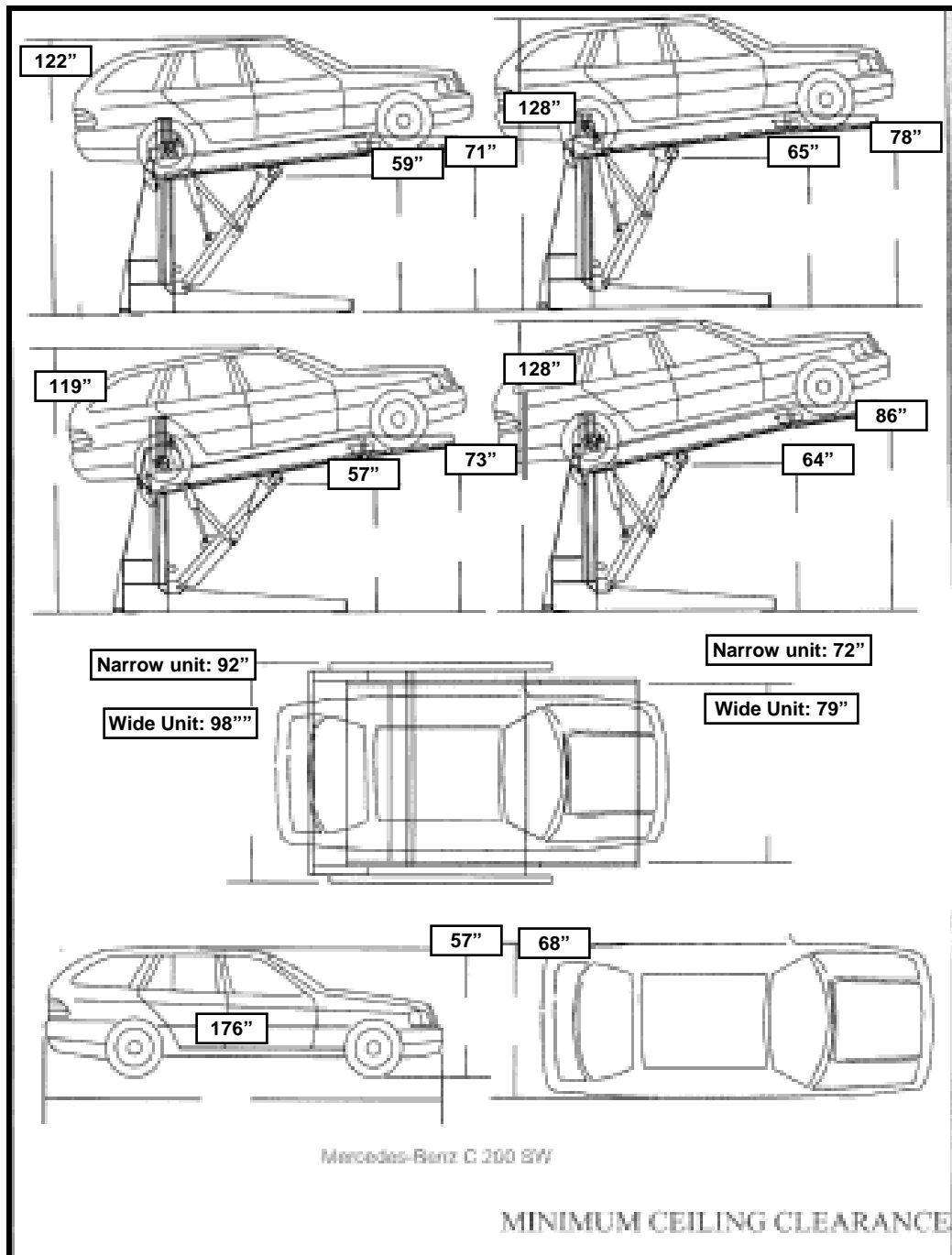

Dimensions are approximate and rounded to nearest whole inch



HARDING
STEEL

Harding Steel Low Model Car Lifts

Ideal for areas with 10' or less of vertical clearance

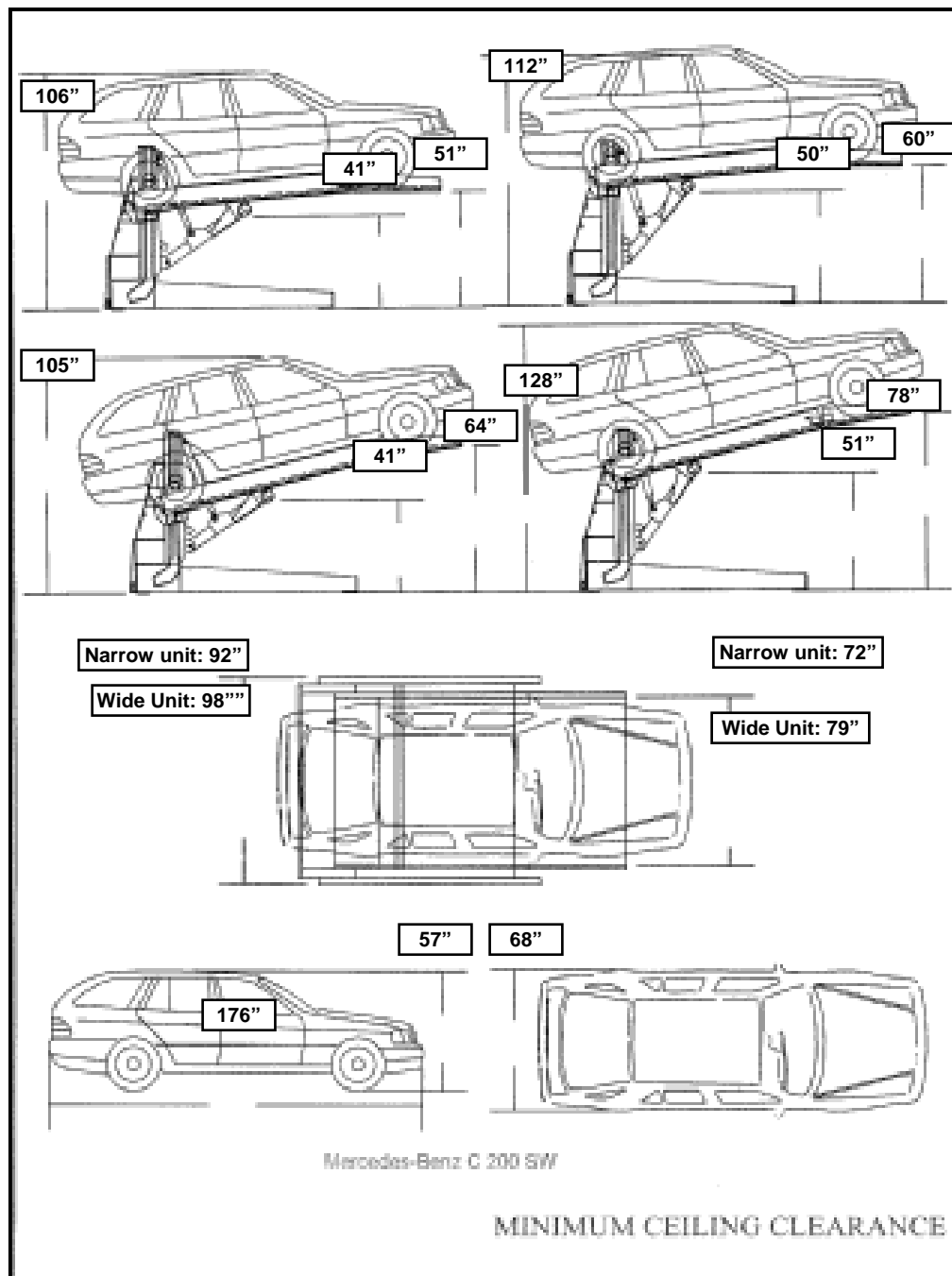

Dimensions are approximate and rounded to nearest whole inch